



TOWER 1  
第1座



ELEVATION PLAN 1  
立面圖 1

TOWER 1  
第1座

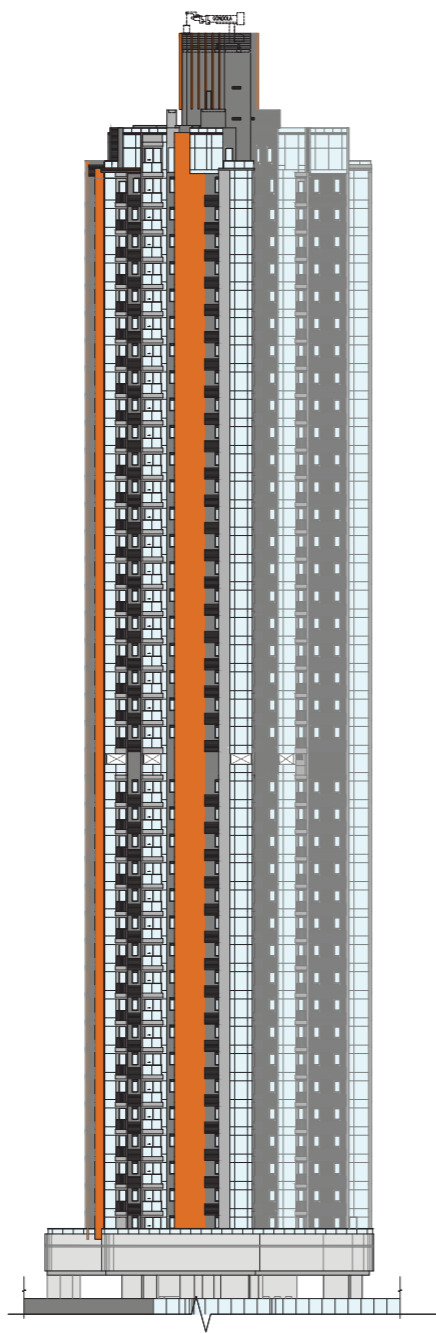

ELEVATION PLAN 2  
立面圖 2

TOWER 1  
第1座

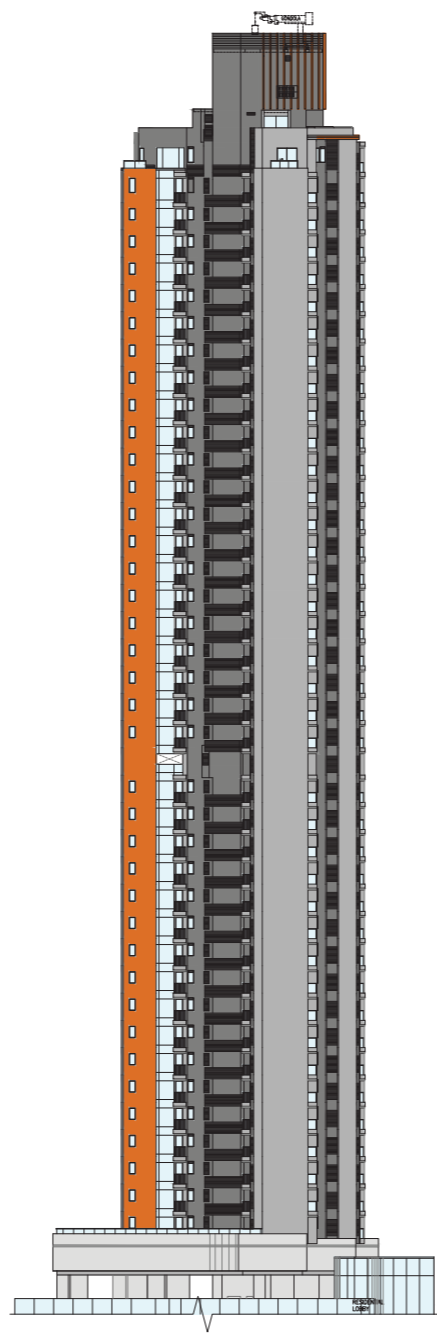

ELEVATION PLAN 3  
立面圖 3

TOWER 1  
第1座

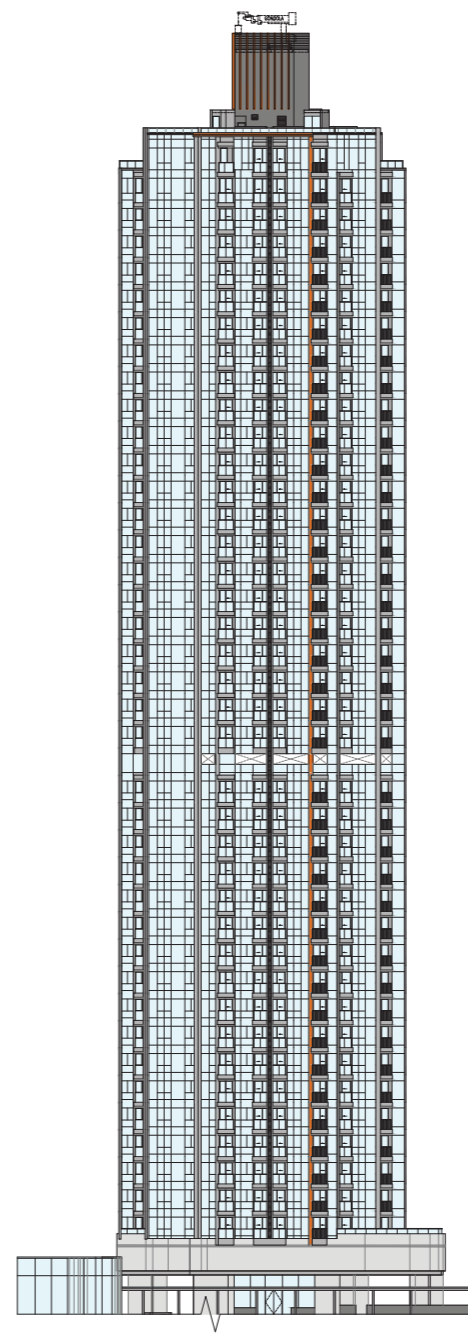

ELEVATION PLAN 4  
立面圖 4

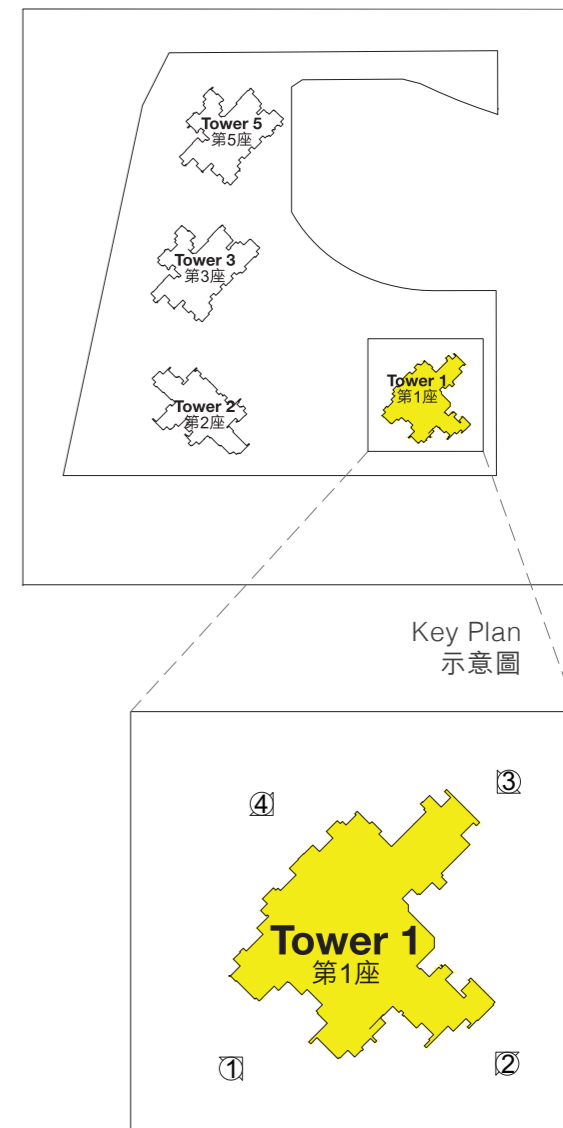

The Authorized Person for the Development has certified that the elevations shown on these plans:  
1. are prepared on the basis of the approved building plans for the Development as of 28 August 2020;  
2. are in general accordance with the outward appearance of the Development.

發展項目的認可人士已證明本圖所顯示的立面：  
1. 以2020年8月28日的情況為準的發展項目經批准的建築圖則為基礎擬備；  
2. 大致上與該發展項目的外觀一致。



TOWER 2  
第2座

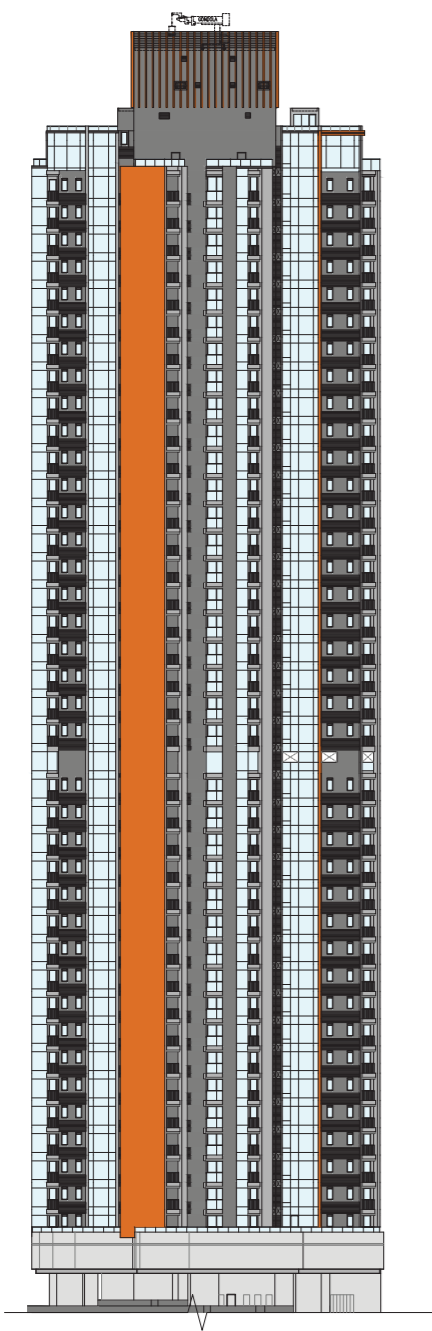

ELEVATION PLAN 1  
立面圖 1

TOWER 2  
第2座

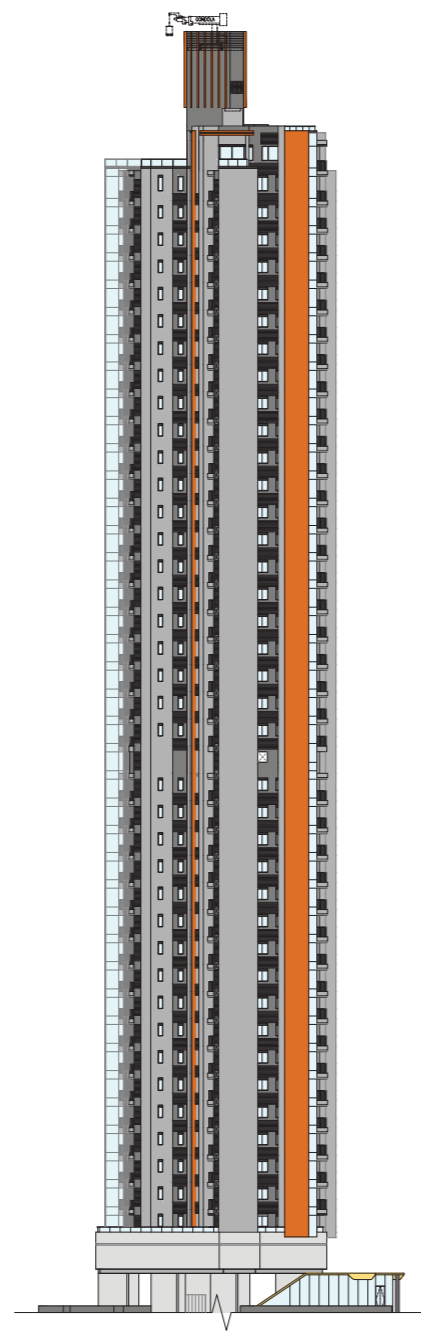

ELEVATION PLAN 2  
立面圖 2

TOWER 2  
第2座

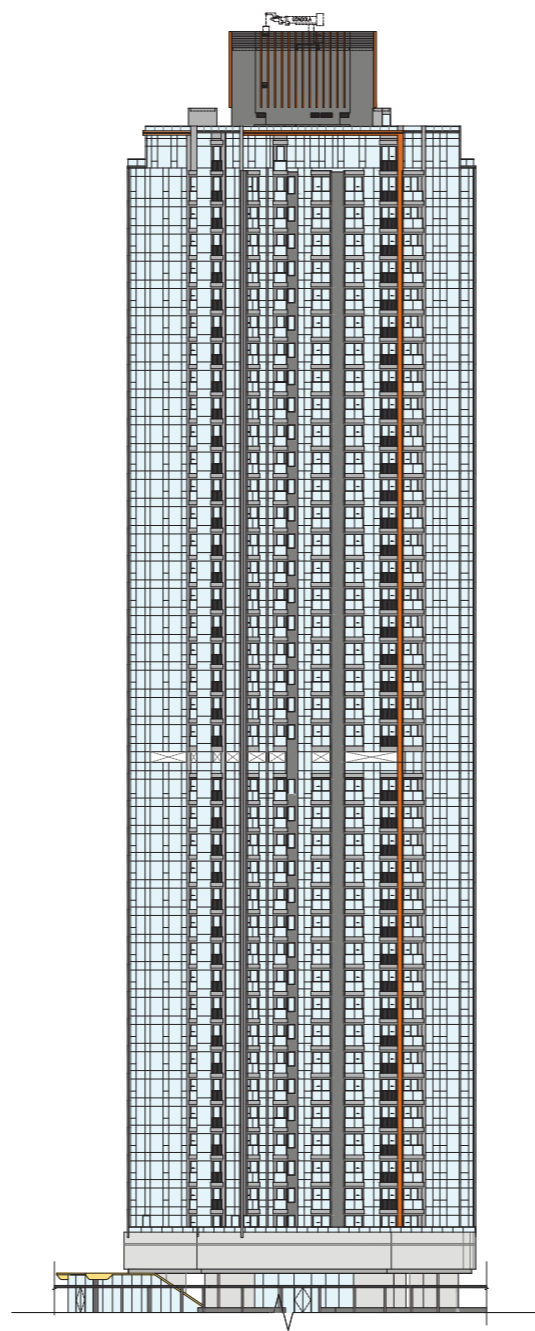

ELEVATION PLAN 3  
立面圖 3

TOWER 2  
第2座

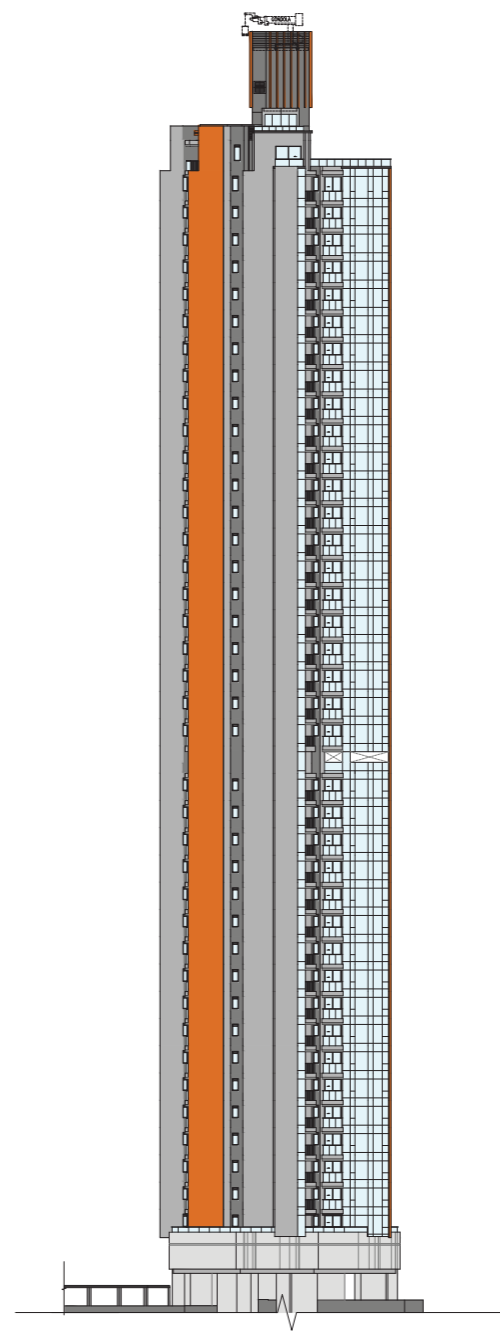

ELEVATION PLAN 4  
立面圖 4

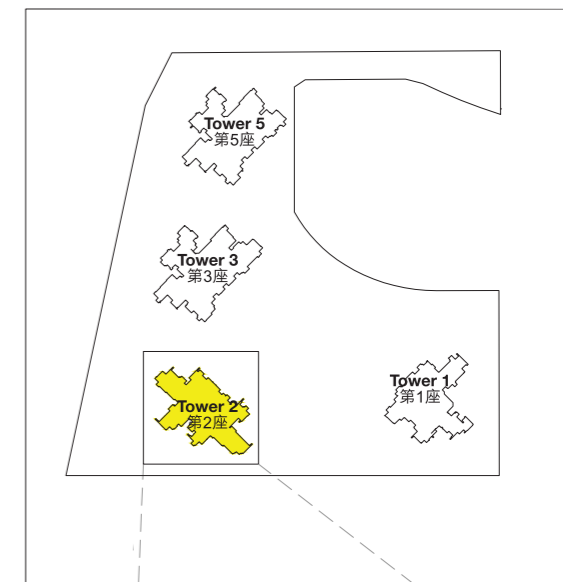

Key Plan  
示意圖

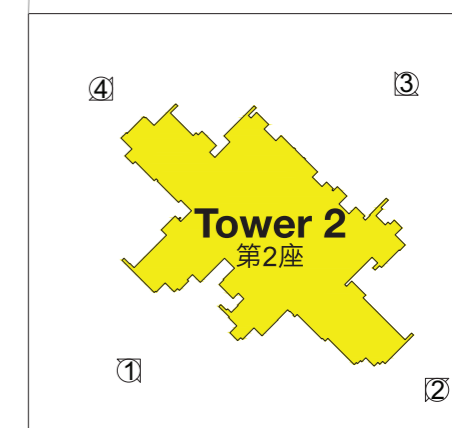

The Authorized Person for the Development has certified that the elevations shown on these plans:  
1. are prepared on the basis of the approved building plans for the Development as of 28 August 2020;  
2. are in general accordance with the outward appearance of the Development.

發展項目的認可人士已證明本圖所顯示的立面：  
1. 以2020年8月28日的情況為準的發展項目經批准的建築圖則為基礎擬備；  
2. 大致上與該發展項目的外觀一致。



TOWER 3  
第3座

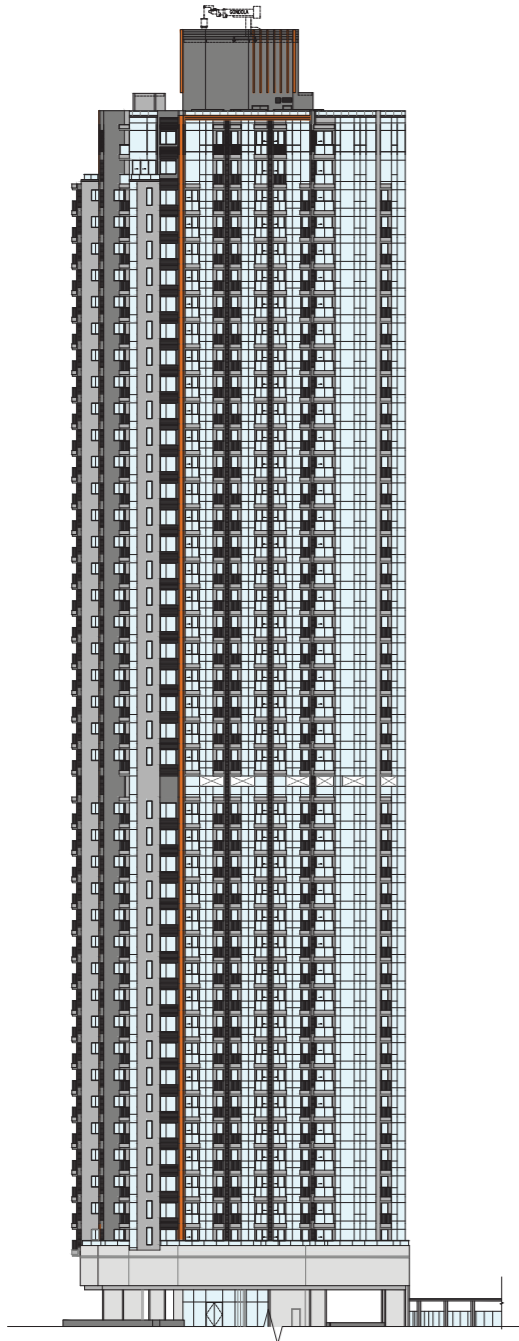

ELEVATION PLAN 1  
立面圖 1

TOWER 3  
第3座

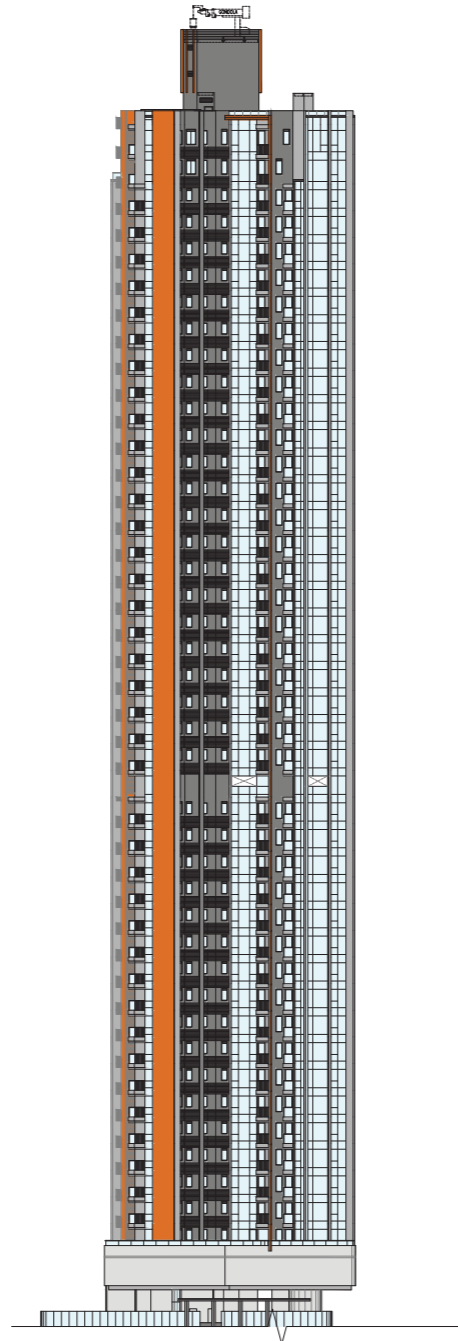

ELEVATION PLAN 2  
立面圖 2

TOWER 3  
第3座

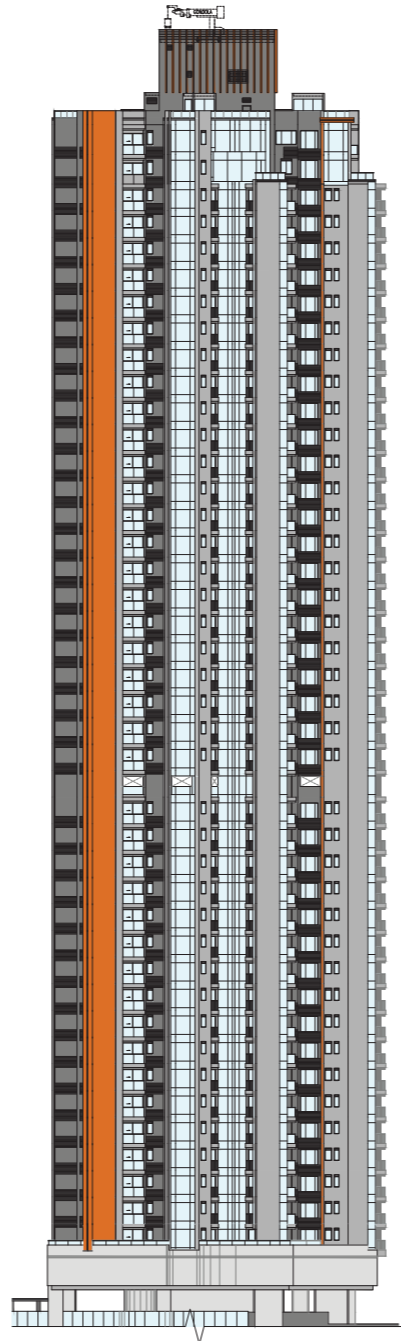

ELEVATION PLAN 3  
立面圖 3

TOWER 3  
第3座

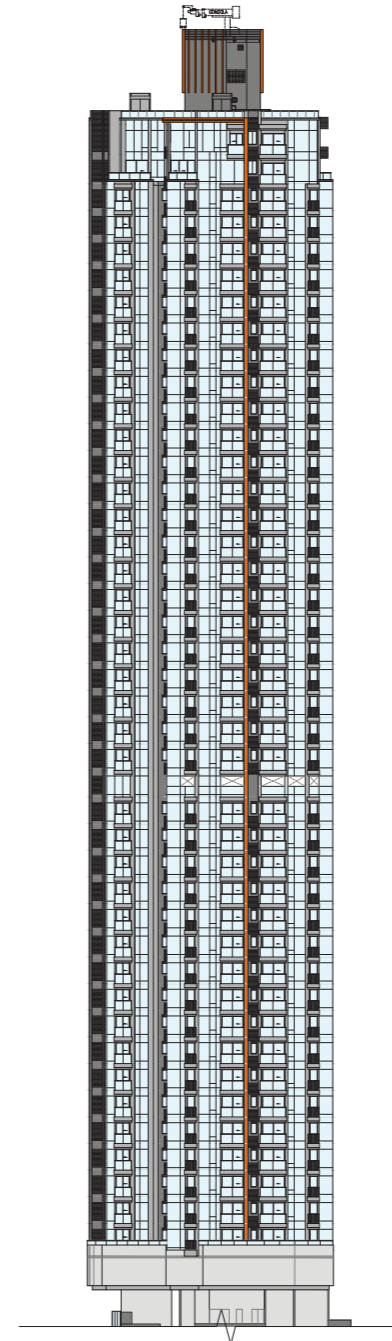

ELEVATION PLAN 4  
立面圖 4

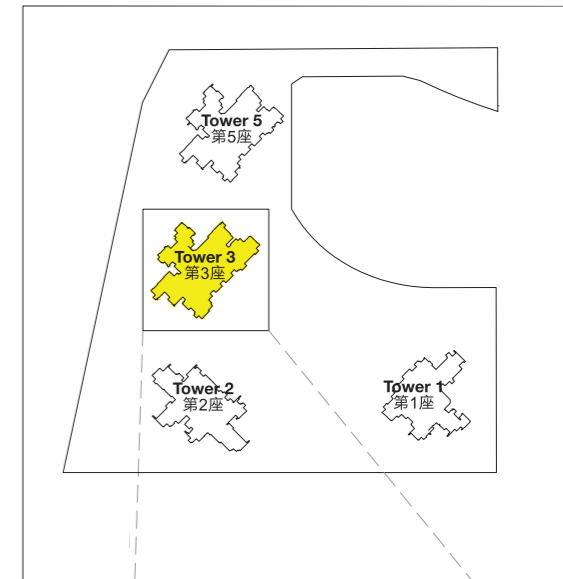

Key Plan  
示意圖

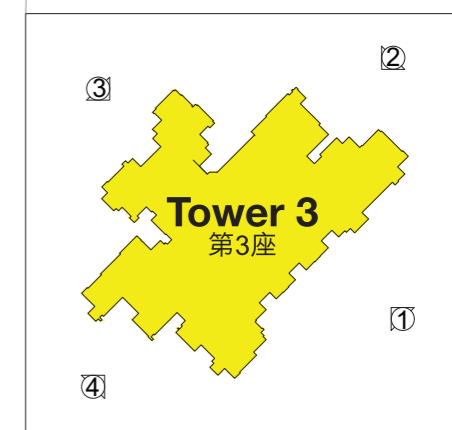

The Authorized Person for the Development has certified that the elevations shown on these plans:  
1. are prepared on the basis of the approved building plans for the Development as of 28 August 2020;  
2. are in general accordance with the outward appearance of the Development.

發展項目的認可人士已證明本圖所顯示的立面：  
1. 以2020年8月28日的情況為準的發展項目經批准的建築圖則為基礎擬備；  
2. 大致上與該發展項目的外觀一致。



TOWER 5  
第5座

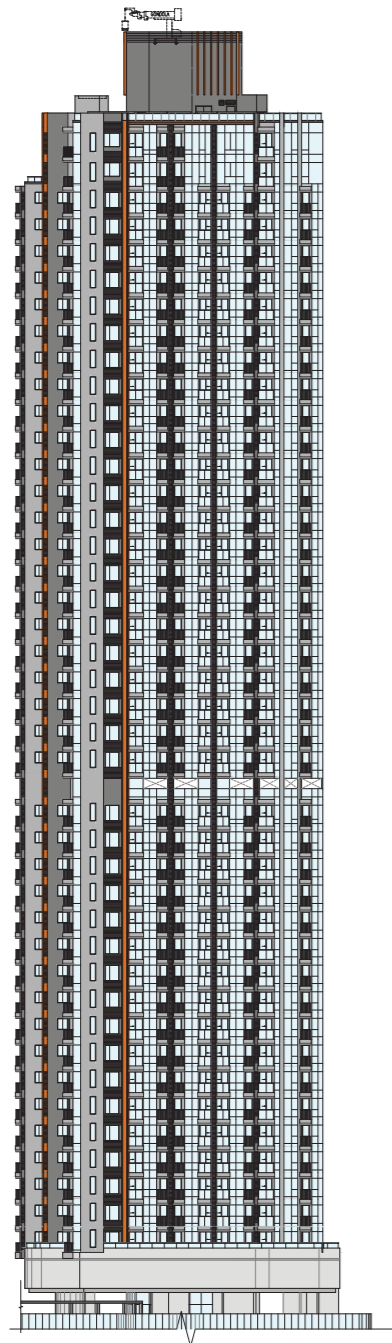

ELEVATION PLAN 1  
立面圖 1

TOWER 5  
第5座

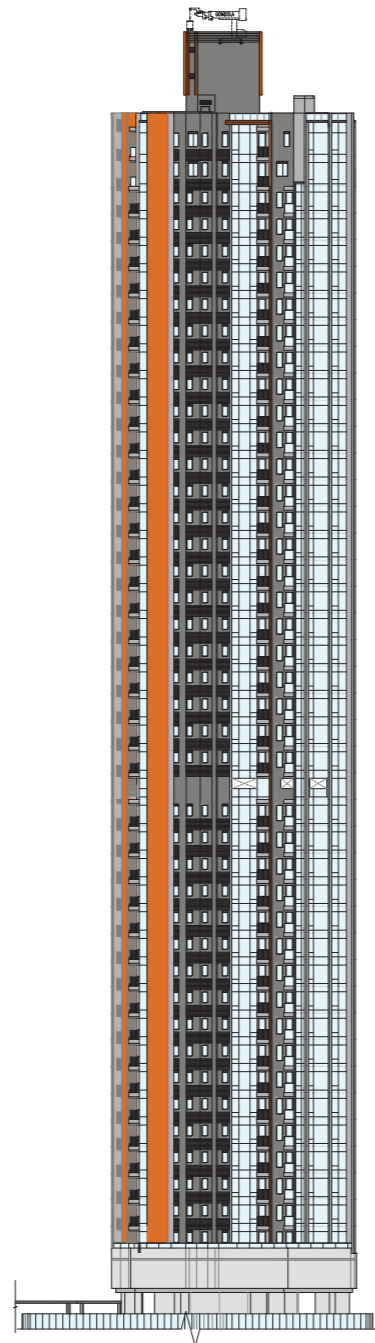

ELEVATION PLAN 2  
立面圖 2

TOWER 5  
第5座

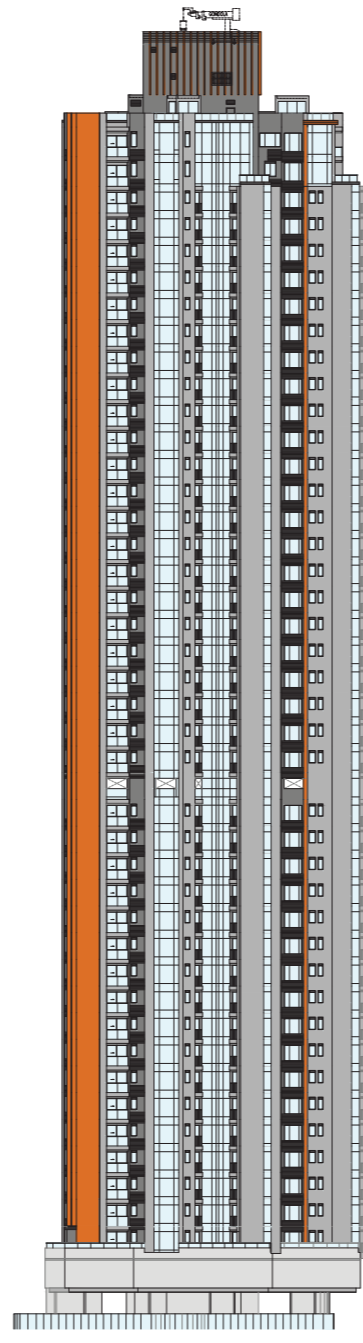

ELEVATION PLAN 3  
立面圖 3

TOWER 5  
第5座

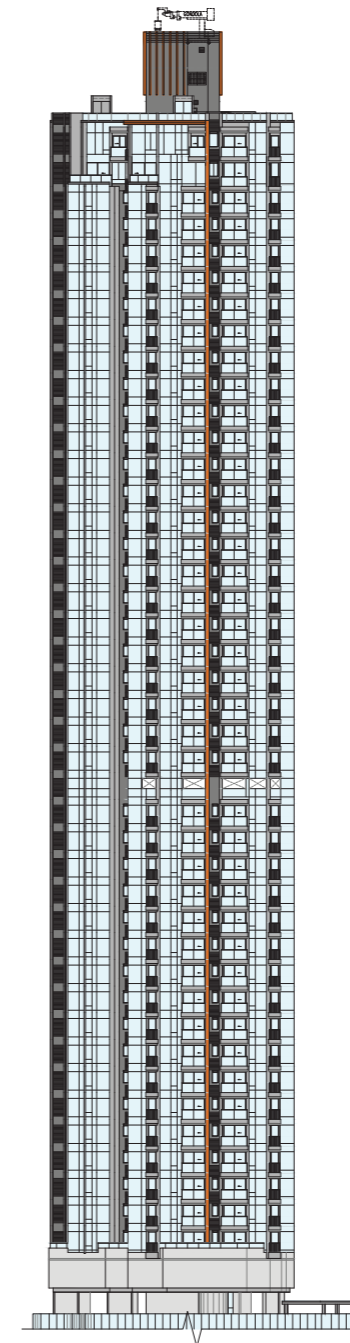

ELEVATION PLAN 4  
立面圖 4

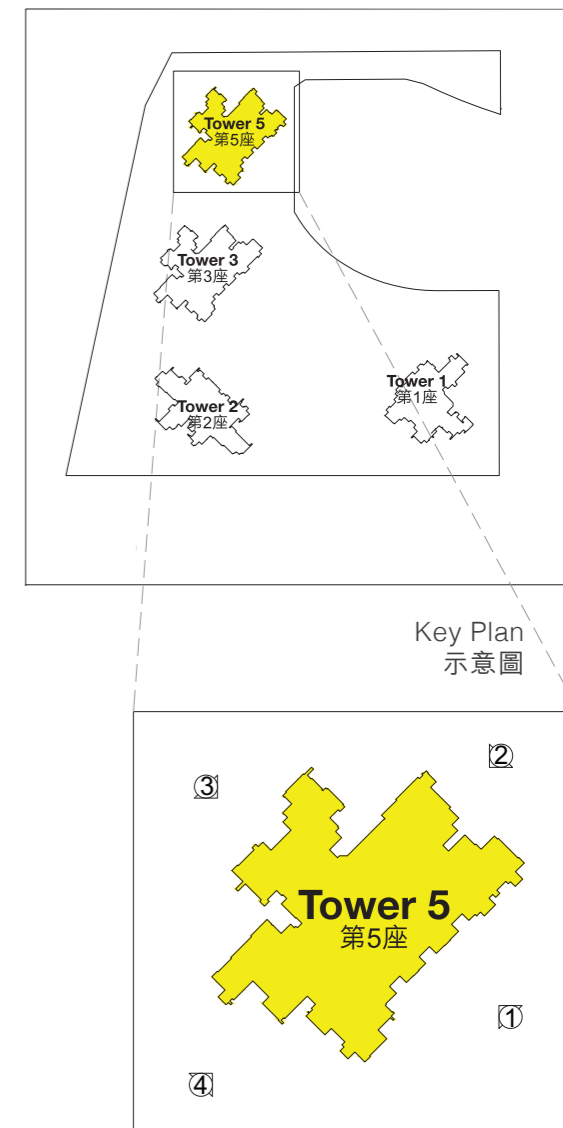

The Authorized Person for the Development has certified that the elevations shown on these plans:  
1. are prepared on the basis of the approved building plans for the Development as of 28 August 2020;  
2. are in general accordance with the outward appearance of the Development.

發展項目的認可人士已證明本圖所顯示的立面：  
1. 以2020年8月28日的情況為準的發展項目經批准的建築圖則為基礎擬備；  
2. 大致上與該發展項目的外觀一致。

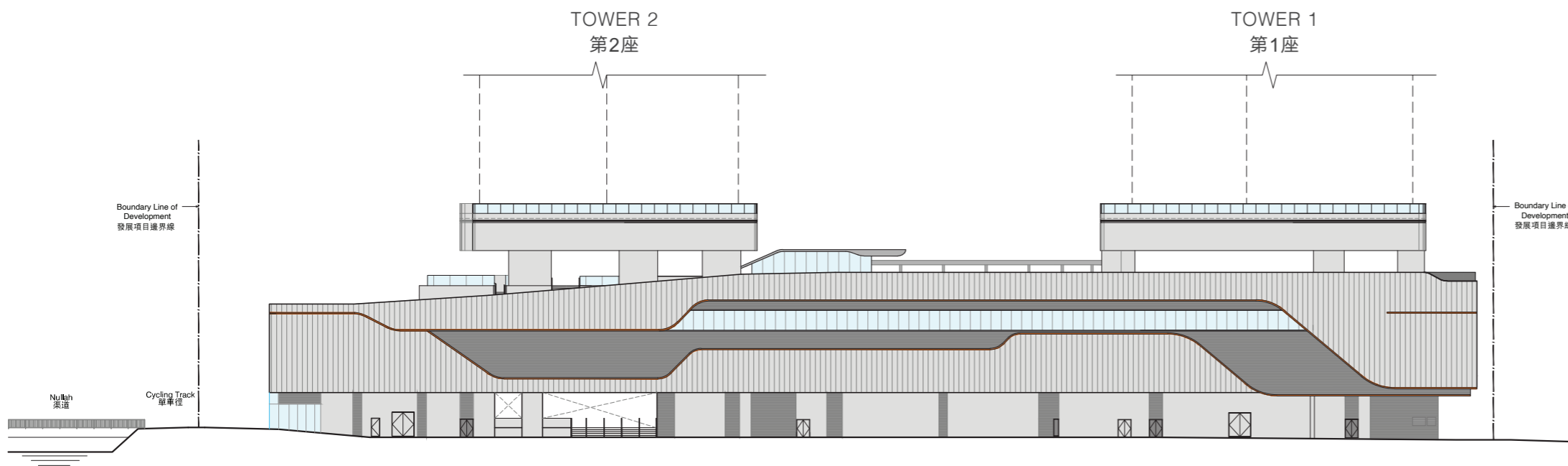

ELEVATION PLAN 1  
立面圖 1

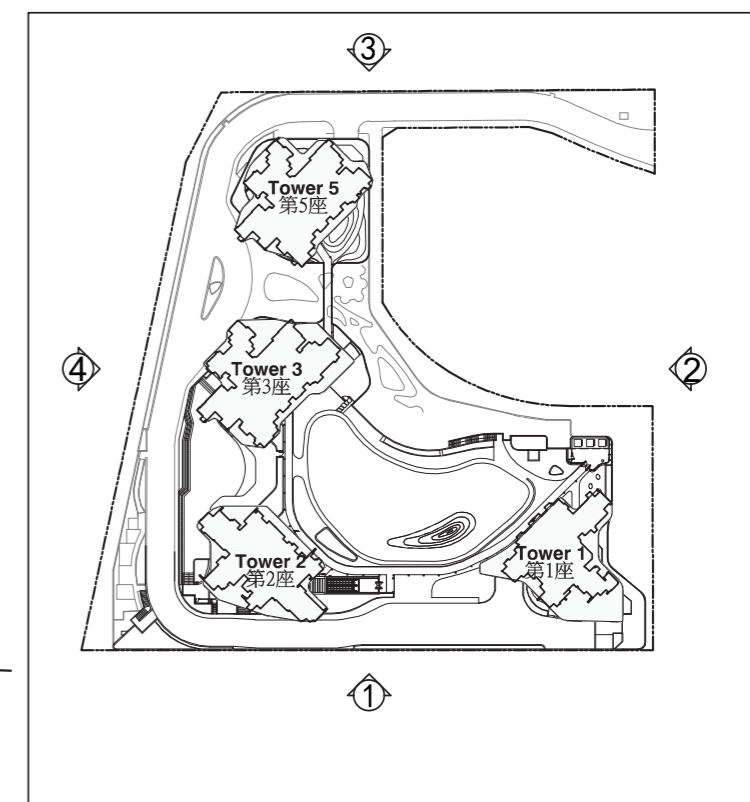

Key Plan  
示意圖

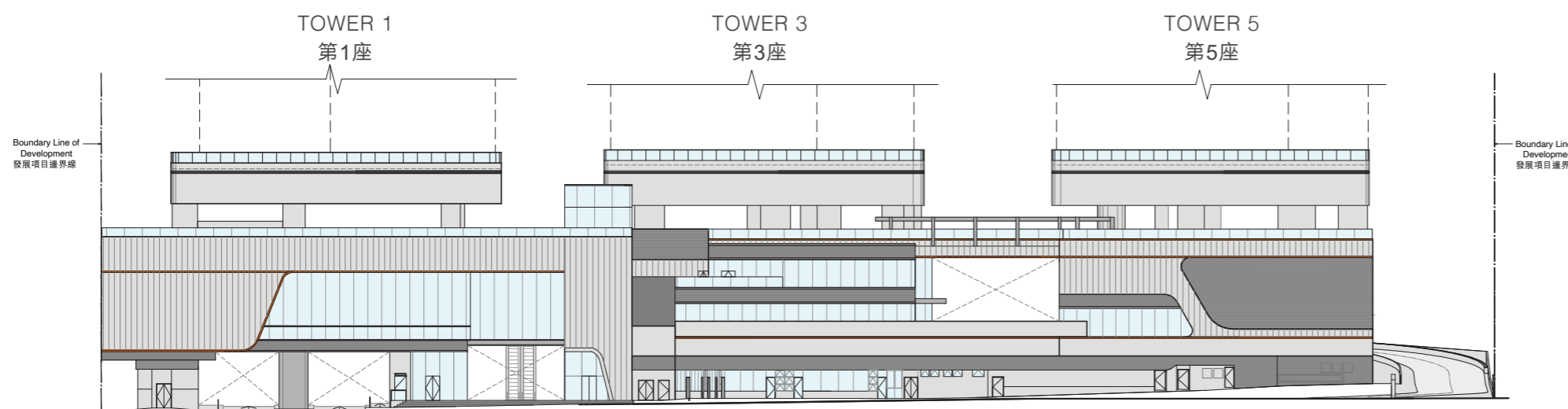

ELEVATION PLAN 2  
立面圖 2

The Authorized Person for the Development has certified that the elevations shown on these plans:  
1. are prepared on the basis of the approved building plans for the Development as of 28 August 2020; and  
2. are in general accordance with the outward appearance of the Development.

發展項目的認可人士已證明本圖所顯示的立面：  
1. 以2020年8月28日的情況為準的發展項目經批准的建築圖則為基礎擬備；及  
2. 大致上與該發展項目的外觀一致。

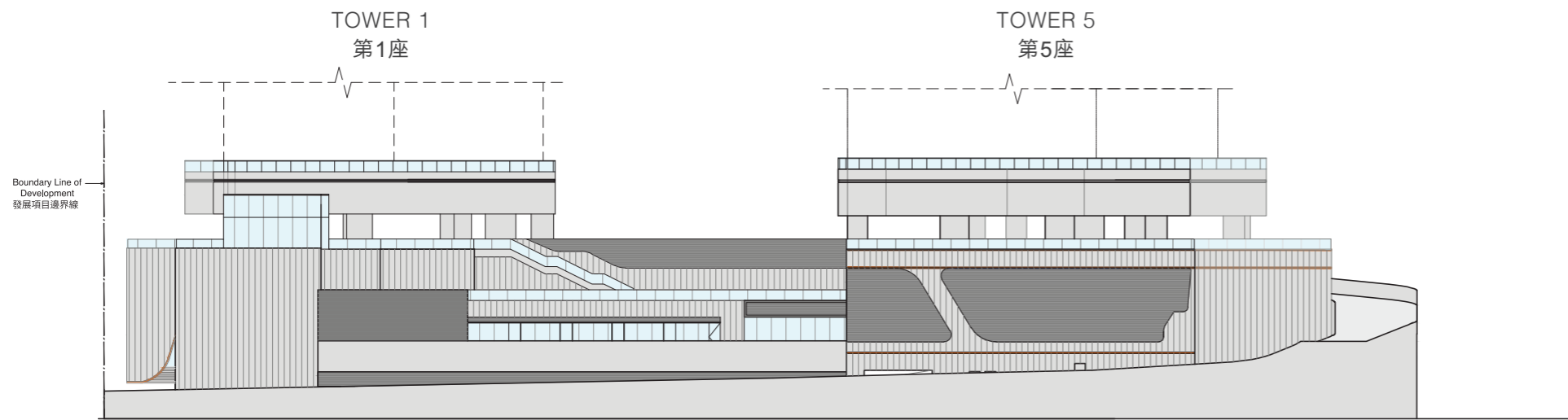

ELEVATION PLAN 3  
立面圖 3

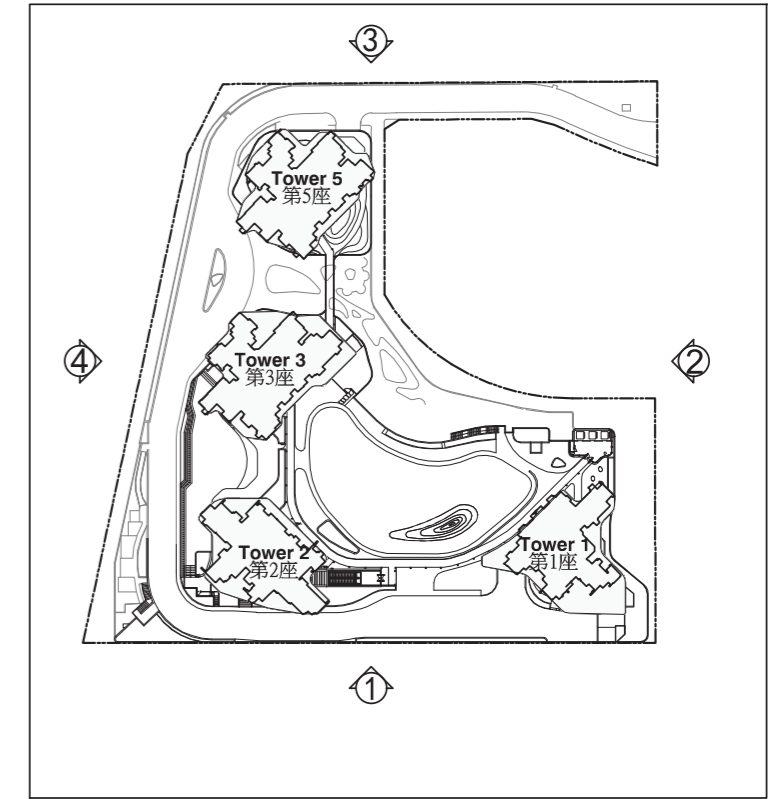

Key Plan  
示意圖

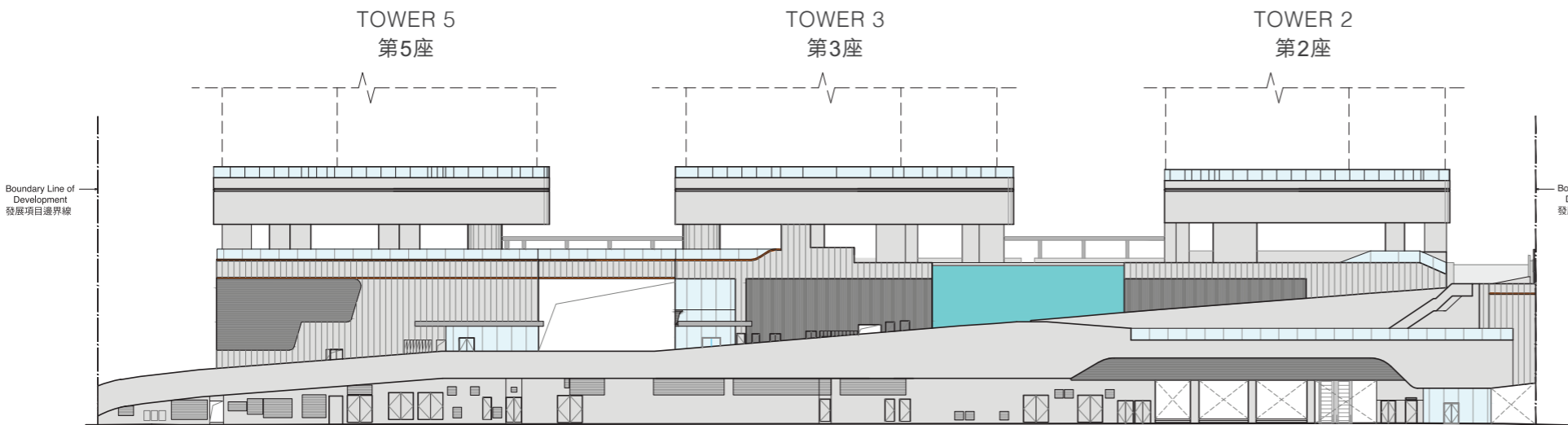

ELEVATION PLAN 4  
立面圖 4

The Authorized Person for the Development has certified that the elevations shown on these plans:  
1. are prepared on the basis of the approved building plans for the Development as of 28 August 2020; and  
2. are in general accordance with the outward appearance of the Development.

發展項目的認可人士已證明本圖所顯示的立面：  
1. 以2020年8月28日的情況為準的發展項目經批准的建築圖則為基礎擬備；及  
2. 大致上與該發展項目的外觀一致。